

## FEATURES

- The face to face conform to :
- DIN 3202 part 3-k4
- Investment casting
- Max working temperature 480°F
- Pressure rating PN 40



### APPLICABLE STANDARD

Test and Inspection	API 598
---------------------	---------

ITEM	PARTS	MATERIAL
1	Body	ASTM A 351 – CF8M
2	Retainer	AISI 316
3	Disc	AISI 316
4	Spring	AISI 316
5	Screw	AISI 316

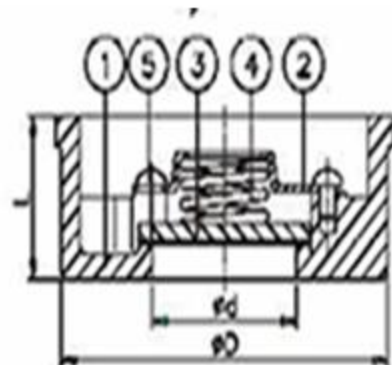
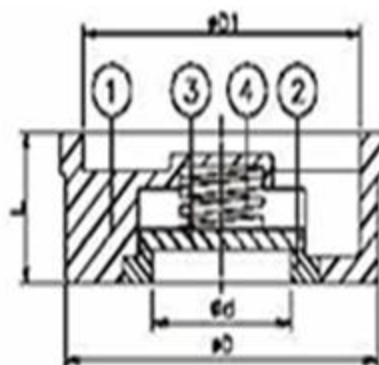

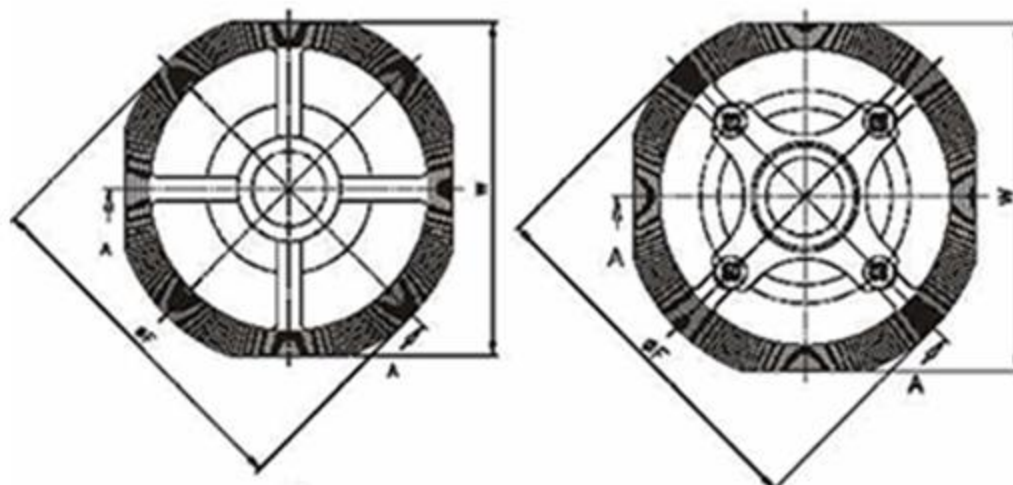

DN	d	D	F	W	L	Weight kg
15	15	45	53	45	16	0.7
20	20	55	63	55	19	0.16
25	25	65	73	65	22	0.28
32	32	78	84	78	28	0.52
40	38	89	98	89	32	0.7
50	50	98	107	98	40	1.1
65	62	118	126	118	46	1.58
80	76.5	134	144	134	50	1.78
100	96	154	162	154	60	3.3

NPS	d	D	F	W	L	weight kg
½"	0.59	1.77	2.09	1.77	0.63	0.22
¾"	0.79	2.17	2.48	2.17	0.75	0.35
1"	0.98	2.56	2.87	2.56	0.87	0.62
1 - ¼"	1.26	3.07	3.31	3.07	1.1	1.15
1 - ½"	1.5	3.5	3.7	3.5	1.26	1.54
2"	1.97	3.86	4.21	3.86	1.57	2.43
2 - ½"	2.44	4.65	4.96	4.65	1.81	3.48
3"	3.01	5.28	5.67	5.28	1.97	3.92
4"	3.78	6.06	6.38	6.06	2.36	7.28