

## • FEATURES

- These valves are suitable for waterworks, mining, agriculture, fishing, marine and general industry.
- They are of metal seated wedge gate design and are available in both bronze fitted and all iron fitted seat versions, with the choice of non-rising or rising stem.

BODY BONNET SHAPE	Oval for greater strength
GUIDES	Long guide in body and on gate to give support to the gate throughout its travel
SEATS	Hydraulically pressed into body
STEM	Strong stub acme or trapezoidal form thread
GLAND BOLT HOUSING	Arranged for easy removal of bolts
MARKINGS	Standard requirements clearly marked on body
STANDARD MATERIALS	
BODY, BONNET, STUFFING BOX, YOKE, GLAND AND HANDWHEEL	Cast iron to SABS 1034 Gr. 250 IBS 1452 Gr. 220 ductile iron to SABS 936 SG 42 IBS 2789 Gr. 420112
SEAT AND GATE RINGS BRONZE FITTED ALL IRON FITTED	Gunmetal BS 1400 Gr. LG2 Integrally cast with body
STEM NUT BRONZE FITTED ALL IRON FITTED	Gunmetal BS 1400 Gr. LG2 Malleable iron
STAM BRONZE FITTED ALL IRON FITTED	High tensile brass BS 2872 Gr. CZ1 14 or stainless steel BS 970:304S 15 mild steel BS 970 Gr. En 3 or stainless steel BS 970 : 304S15
JOINTING	Klingerite
PACKING	Graphited fibre

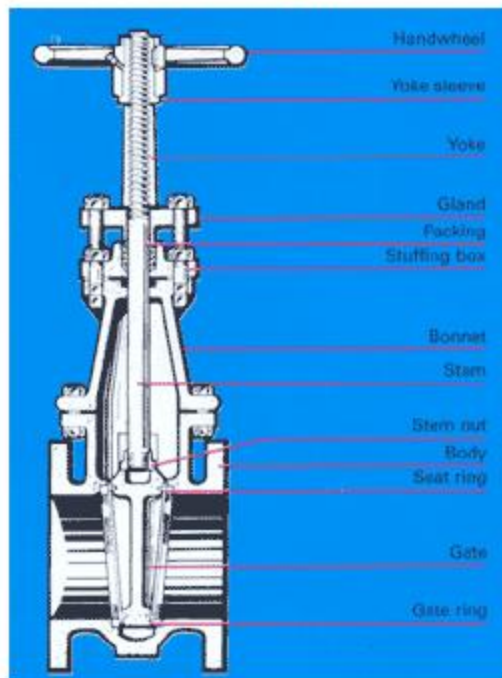
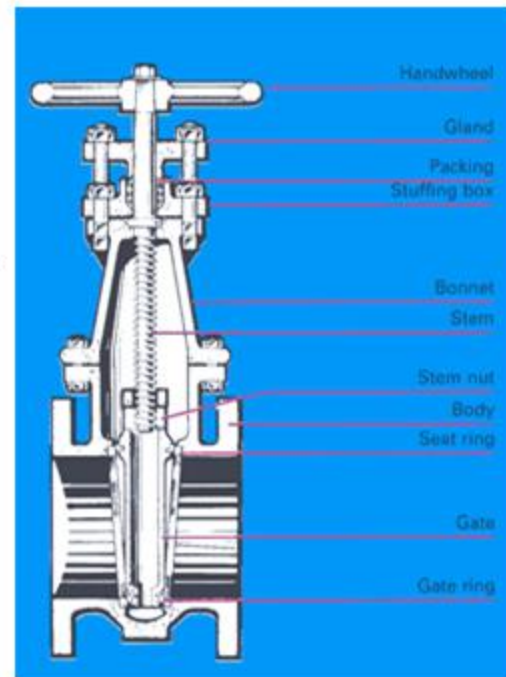

[Click here to zoom](#)[Click here to zoom](#)

## BONNET VARIATIONS

### RIISING STEM

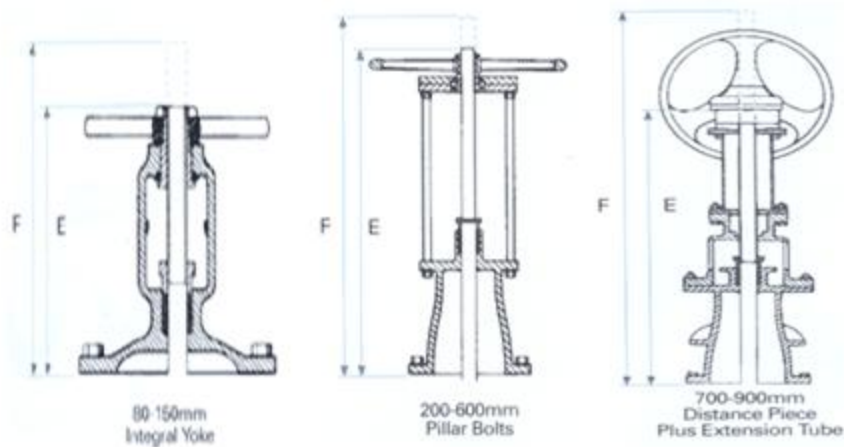
[Click here to zoom](#)

### BODY END CONNECTIONS

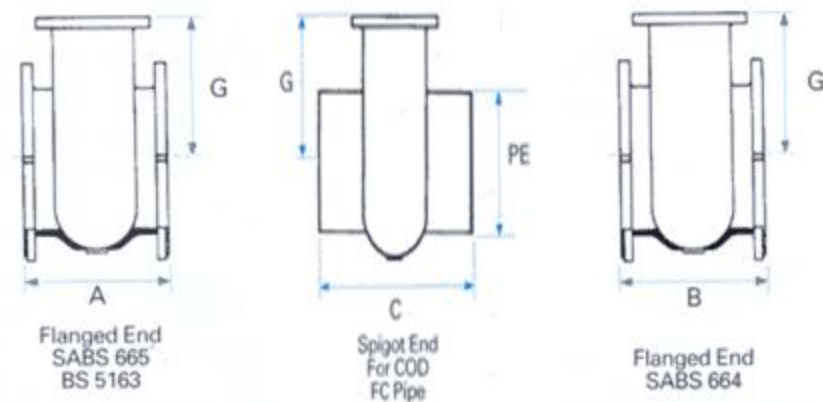
[Click here to zoom](#)

**VALVE DIMENSIONS**

NOMINAL BORE		80	100	150	200	250	300	350	400	450	500	600	700	800	900
FACE TO FACE SABS 665 or BS5150/ BS 5163	A	203	229	267	292	330	356	381	406	432	457	508	610	660	711
FACE TO FACE SABS 664	B	229	254	280	317	356	380	470	470	485	510	600	610	660	711
LENGTH	C	280	305	362	420	470	520	-	-	-	-	-	-	-	-
BONNET FLANGE TO STEM TOP (N/R)	D	242	242	383	421	508	541	684	716	845	884	942	1288	1378	1482
BONNET FLANGE TO STEM TOP (CLOSED)	E	262	262	445	574	613	712	923	1026	1120	1218	1377	1739	1794	2126
BONNET FLANGE TO STEM TOP (OPEN)	F	345	370	615	803	880	1030	1288	1453	1597	1755	2010	2445	2606	3075
CENTRE TO BONNET FLANGE	G	168	210	194	240	292	343	375	454	501	533	656	750	820	980
SPIGOT DIAMETER	PE	95	122	177	232	286	345	-	-	-	-	-	-	-	-
HANDWHEEL DIA N/R		250	315	400	400	500	500	610	610	610	610	610	750	750	750
HANDWHEEL DIA R/S		200	250	380	380	500	500	610	610	610	610	610	750	750	750
MASS (approx) (kg) N/R		25	32	57	96	165	215	428	472	630	750	1082	1810	2130	2950
MASS (approx) (kg) R/S		27	34	62	100	172	223	434	503	646	781	1148	1880	2220	3070